

# ASSEMBLY INSTRUCTIONS:

## 52054 QUEEN HEADBOARD

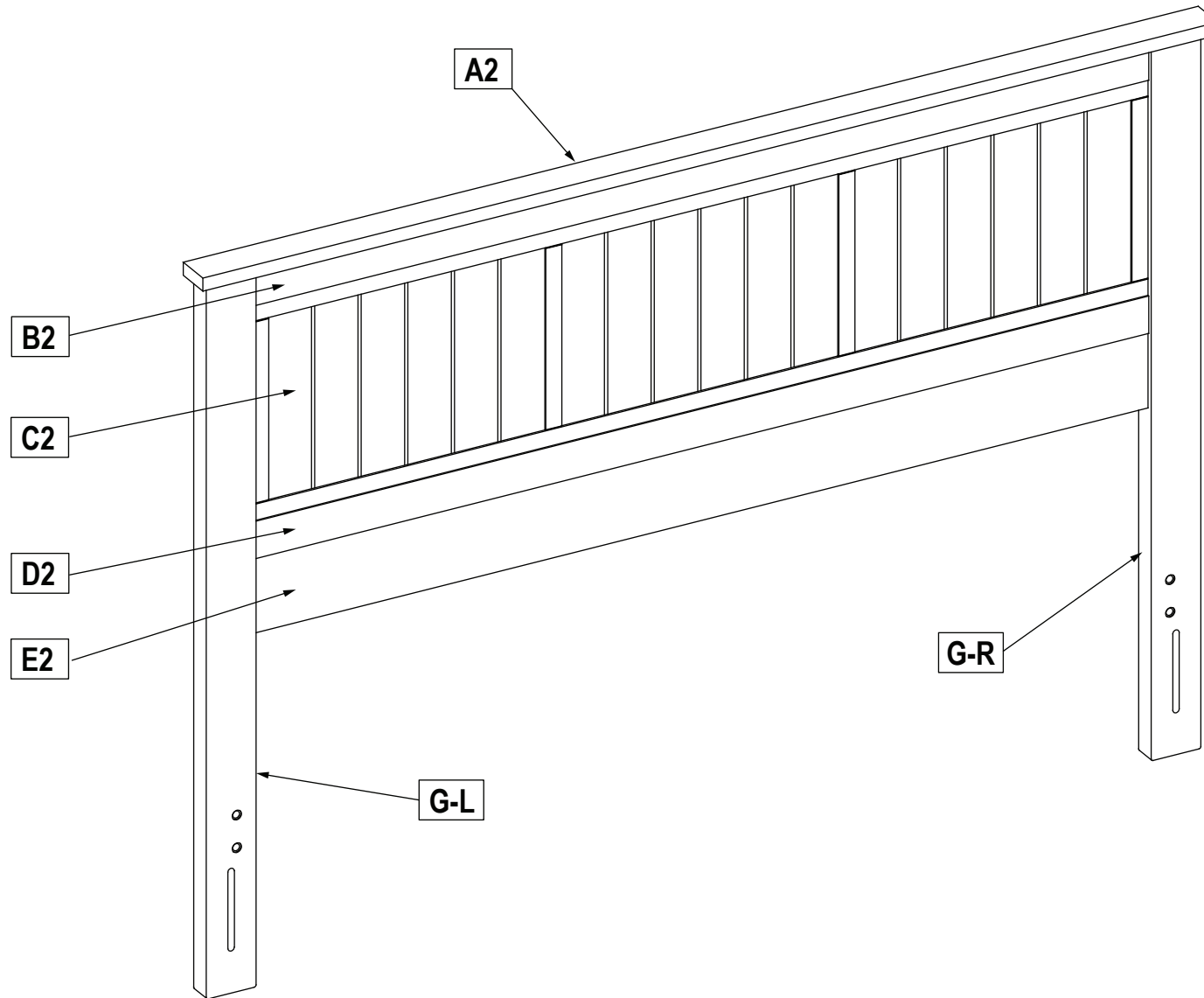

# 52054 QUEEN HEADBOARD

## ASSEMBLY INSTRUCTIONS

Read these instructions carefully and keep for future reference. Refer to parts inventory for guidance, and ensure you have all pieces before starting.

When assembling, place all parts on a soft, clean, and flat surface such as a carpet to prevent scratches.

**If you're having difficulty, our friendly Customer Care team is always here to help. Call us at 1.336.861.0604 during business hours, email [parts@comfortpointe.com](mailto:parts@comfortpointe.com).**

Attention : Veuillez Lire Toutes Les Instructions Avant De Commencer L'assemblage De Ce Produit. Les Pièces Sont Lourdes. Pour Éviter Toute Blessure Et Pour Vous Assurer Que Le Produit N'est Pas Endommagé Pendant L'assemblage, Nous Vous Recommandons De Faire Appel À Une Ou Plusieurs Autres Personnes.

Cuidado: Favor De Leer Todas Las Instrucciones Antes De Ensamblar Su Producto. Estas Piezas Son Pesadas. Para Prevenir Heridas Personales Y Asegurar Que Su Producto No Sea Dañado Mientras Es Ensamblado, Se Recomienda La Asistencia De Una O Más Personas.



TIME

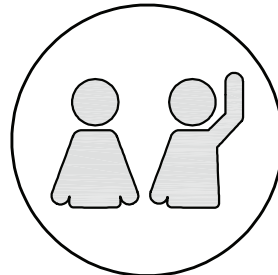

# OF PEOPLE

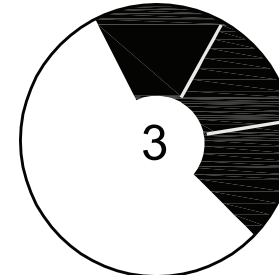







DIFFICULTY

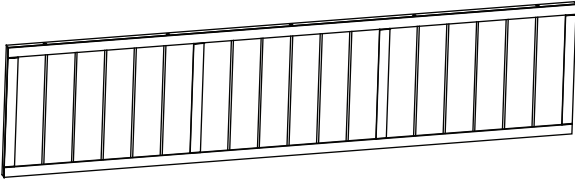

**Important: Use hand tools for assembly. Power tools can lead to over-tightening and damage.**

# 52054 QUEEN HEADBOARD

## Parts List

CODE	DESCRIPTION	QTY
A2	Headboard Top 	1 pc
B2	Crossbar Top 	1 pc
C2	Headboard 	1 pc
D2	Crossbar 	1 pc
E2	Crossbar Bottom 	1 pc
G-L	Left Leg 	1 pc
G-R	Right Leg 	1 pc

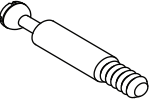
## Hardware List

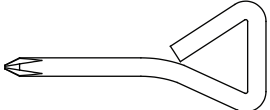
CODE	DESCRIPTION	QTY
1	Dowel Ø8x30mm 	6 pcs
2	Camlock Bolt Ø1/4"x1-3/8" 	19 pcs
3	Camlock Ø15 	19 pcs
4	Philips Head Screwdriver 	1pc

# 52054 QUEEN HEADBOARD

1

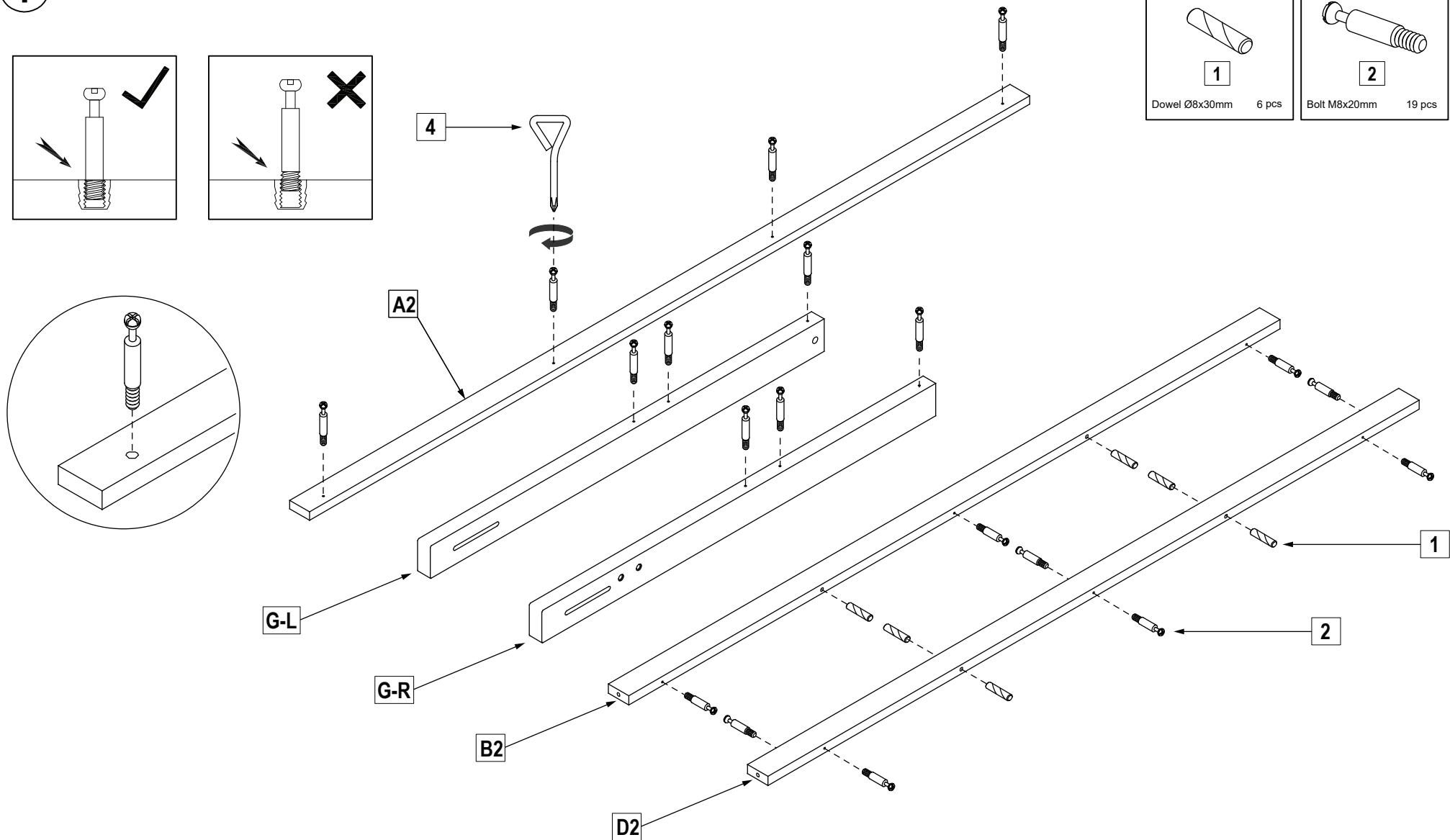
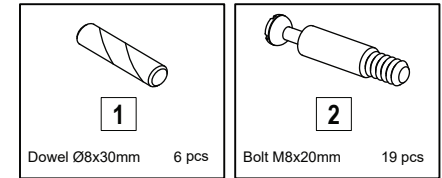
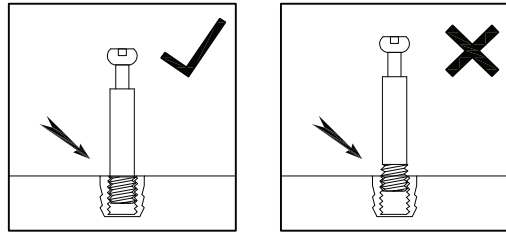

If you're having difficulty, our friendly Customer Care team is always here to help. Call us at 1.336.861.0604, email: [parts@comfortpointe.com](mailto:parts@comfortpointe.com).

2

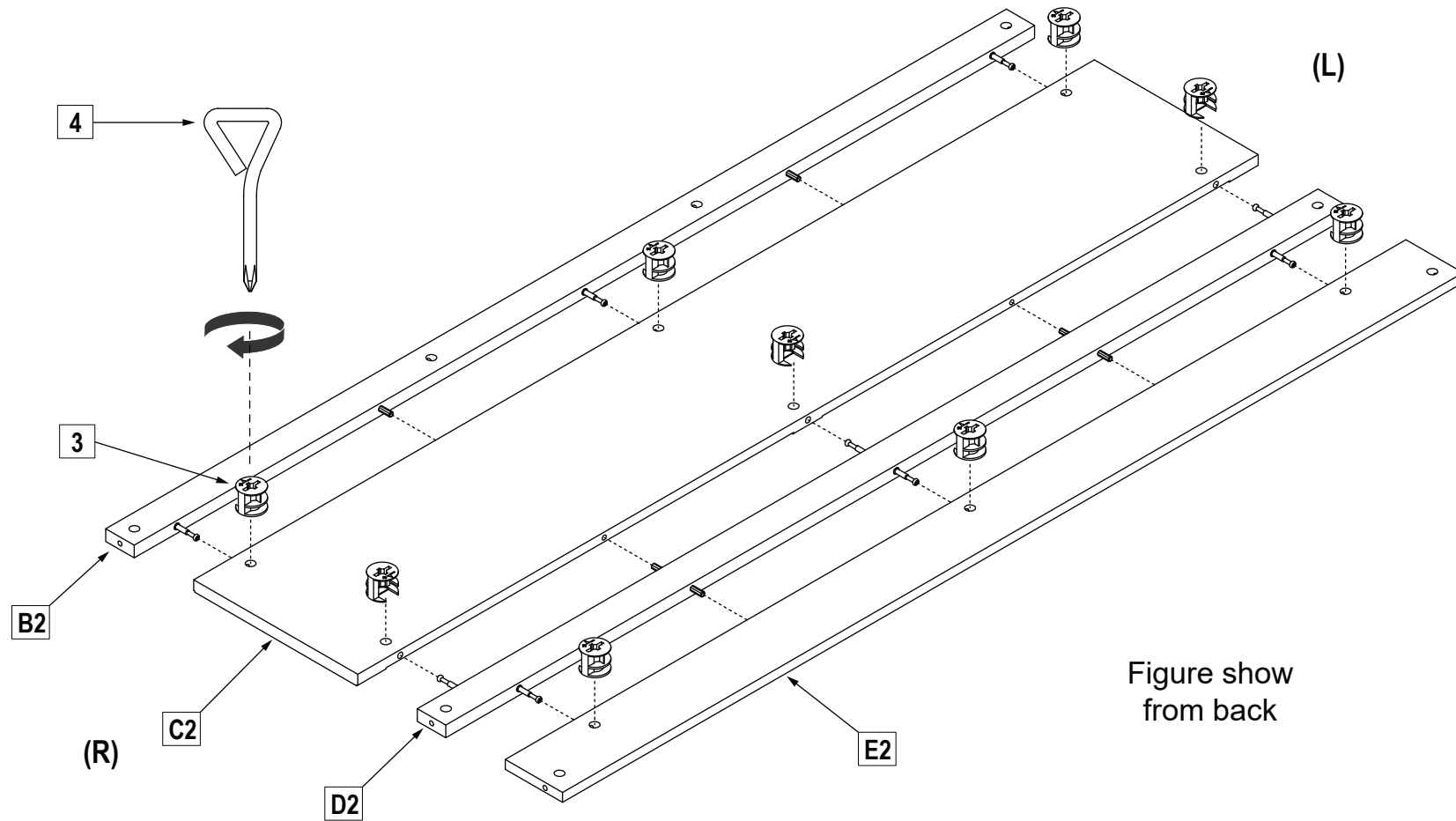
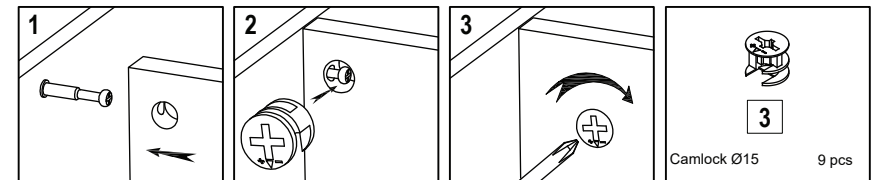
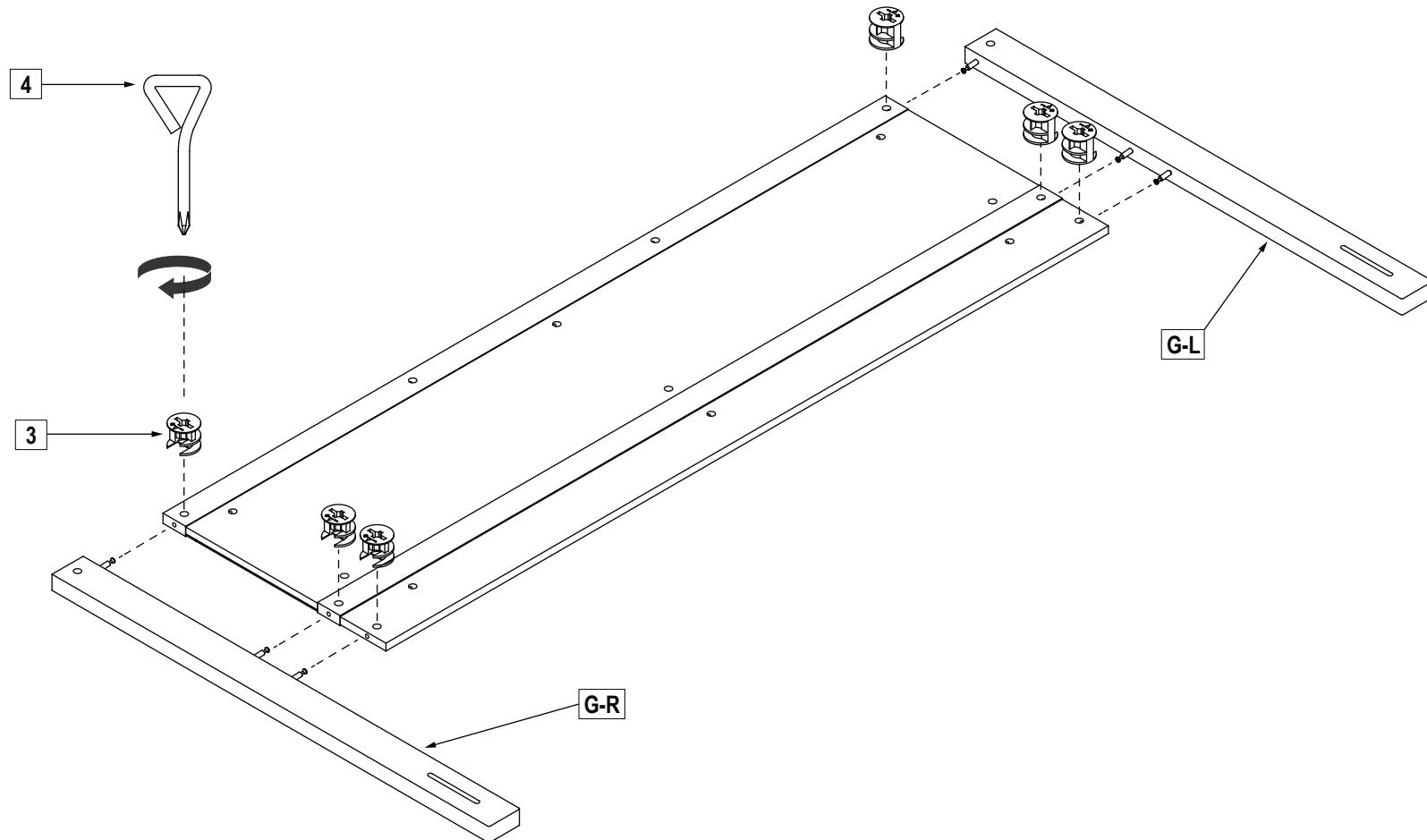
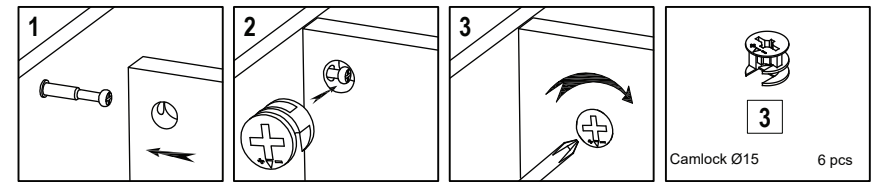

Figure show from back

If you're having difficulty, our friendly Customer Care team is always here to help. Call us at 1.336.861.0604, email: [parts@comfortpointe.com](mailto:parts@comfortpointe.com).

3



If you're having difficulty, our friendly Customer Care team is always here to help.  
Call us at 1.336.861.0604, email: [parts@comfortpointe.com](mailto:parts@comfortpointe.com).

4

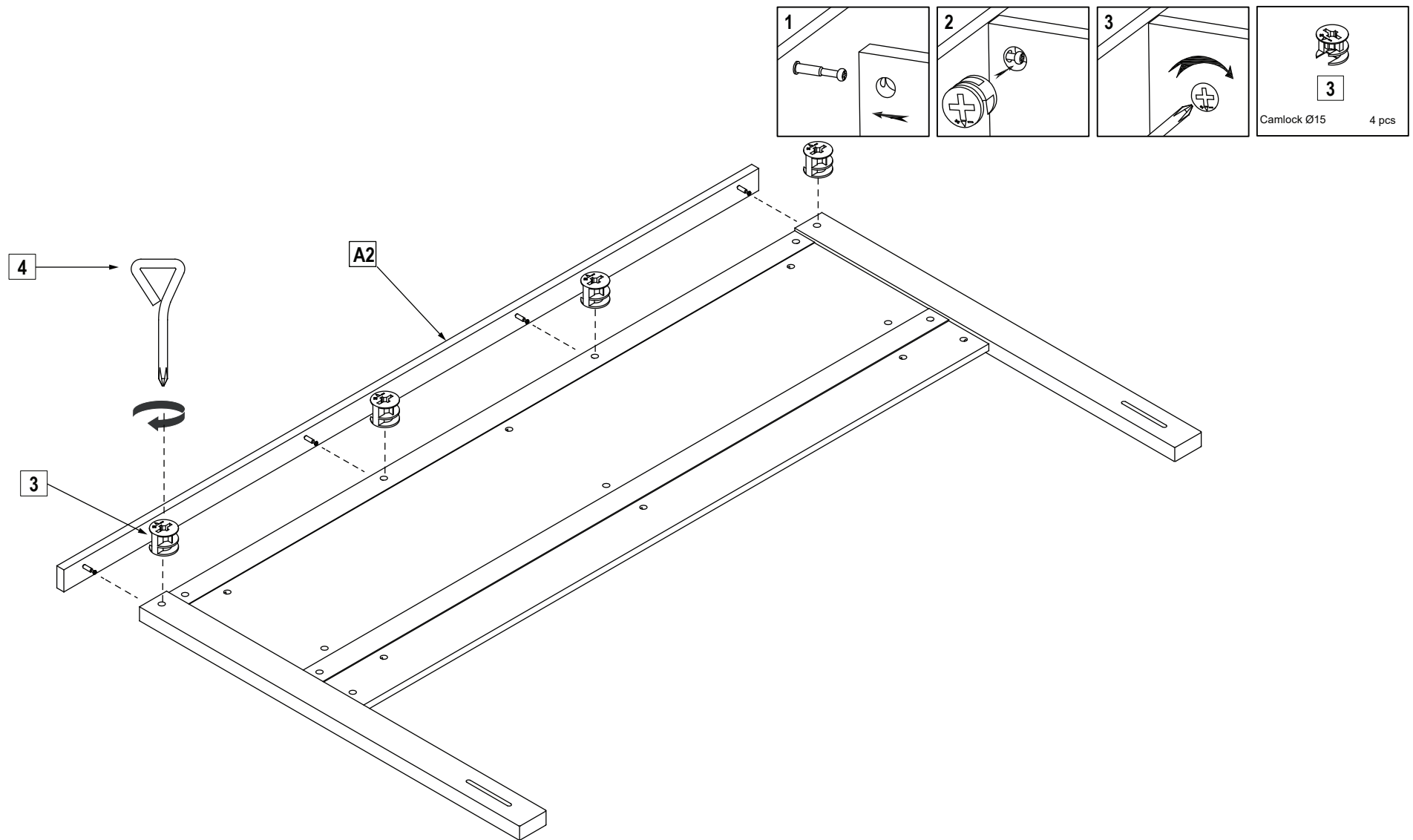

If you're having difficulty, our friendly Customer Care team is always here to help.  
Call us at 1.336.861.0604, email: [parts@comfortpointe.com](mailto:parts@comfortpointe.com).

5

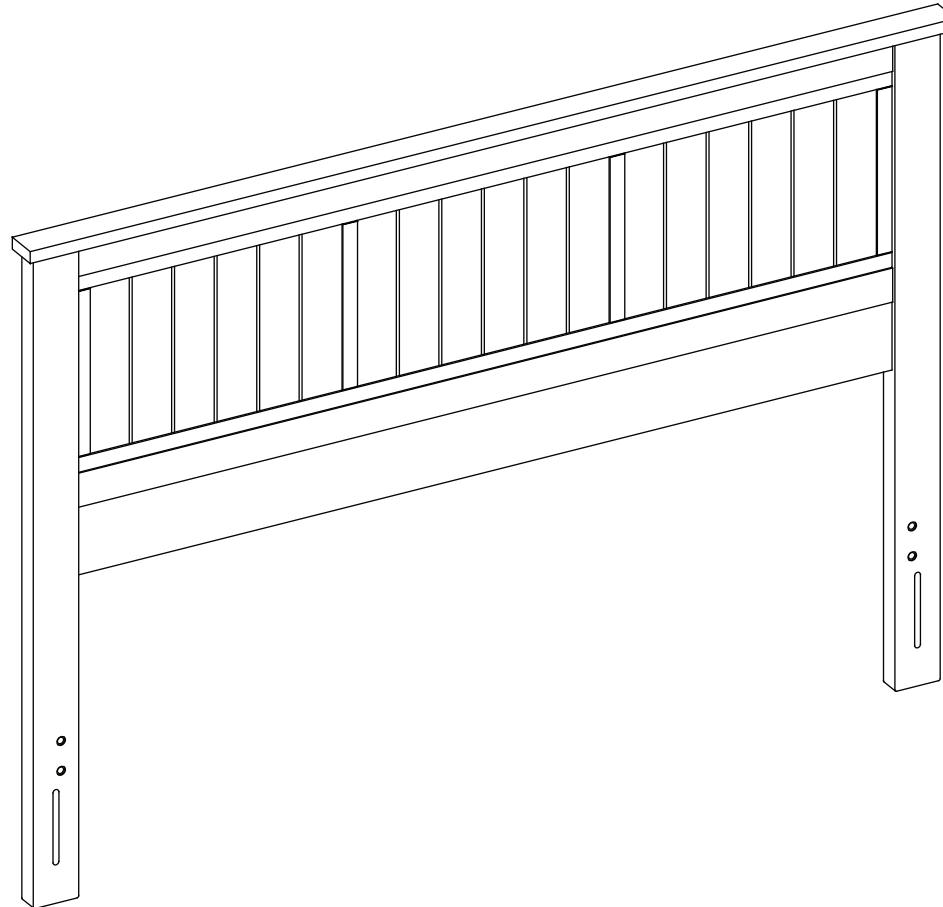

Attach the frame to the headboard using the long slots located on the lower portion of the legs of the headboard (hardware not included), these are designed to accommodate varying height bed frames. The holes with inserts are used with the bed frame that We produce for the headboard only.

#### Hardware/Assembly Tips:

With the headboard in position to be mounted to the frame, measure the length from the back of the headboard to the inside of the bedframe, allow enough additional length to add a couple of washers and a nut to secure the headboard to the frame.

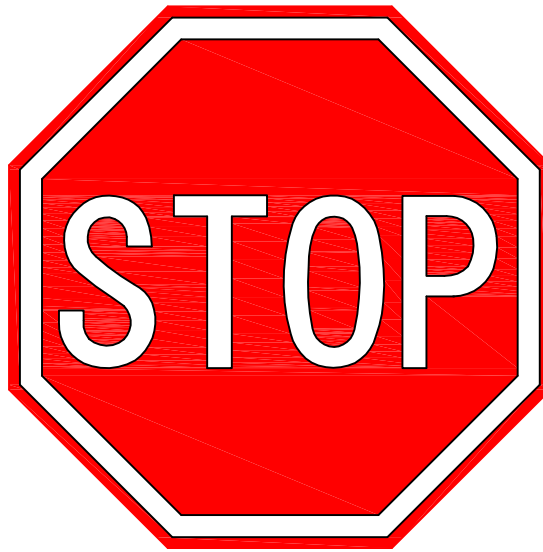

\*\*\*\*\*IMPORTANT MESSAGE\*\*\*\*\*

Please check to insure you have received all parts listed on the instruction sheet provided. If you did not receive all parts or received damaged parts please email or call the following:

Email : [Parts@comfortpointe.com](mailto:Parts@comfortpointe.com)

Phone : 336-861-0604 Contact : PartsDepartment

Office hours :

8am to 4pm EST Mon-Thur

8am to 3pm EST Friday

You will need to provide the item number purchased, your reference number, and identify which part is missing/damaged, all parts orders are considered priority.

Thank You